

December 14, 2017

Letter Report No. 103295707COQ-001D

Stephen Thornton  
Excell Railing Systems Ltd.  
306 – 12886 Anvil Way  
Surrey, BC V3W 8E7  
Canada

Ph: 604-501-0151  
Fx: 604-501-0155  
email: stevet@excellrailing.com

**Subject: Findings Letter Report 103295707COQ-001D**

Dear Mr. Thornton,

Intertek has conducted concentrated load testing on your aluminium post products in accordance with Section 1607.8.1.1 *Concentrated Load* of the 2015 International Building Code (IBC). The post samples were submitted to the Evaluation Center on November 16, 2017 (Coquitlam ID# VAN1711220828-001) and December 6, 2017 (Coquitlam ID# VAN1712111006-001). Refer to Appendix for drawings of each post. Each post was placed into a universal testing frame and loaded using a 5k lbf capacity S-type load cell (Intertek ID# P60692, cal due August 4, 2018) and hydraulic ram. The samples were loaded to 500 lbf and held for a period of 1 minute. Upon completion of the proof load, the posts were further loaded until failure. Testing has been completed and results of the testing can be found below:

Table 1. Test Results			
Description	Ultimate Load (lbf)	500 lbf Proof Load	Mode of Failure
Knotwood 2-9/16 in. post @ 42 in., 4x4x3/8 x 8 screws 3 in. long (#12 x 3 in. Robertson Flat Kwixin Aster Zinc Steel); pre-drilled 11/64 in. post screw chase for base plate screws	551	Pass	Screw heads attaching baseplate to post broke
Knotwood 2-9/16 in. post @ 46 in., inside welded fascia pocket, 4 screws #14 x 1 tek hex screws (2 each side)	536	Pass	Post kinked at top of fascia bracket

If there are any questions regarding the results contained in this report, or any of the other services offered by Intertek, please do not hesitate to contact the undersigned.

Completed by: Chris Chang, P.Eng.  
Engineer  
Building Products  
Title:  
Signature:  

Reviewed by: Baldeep Sandhu  
Manager  
Building Products  
Title:  
Signature:  



## **APPENDIX A: DRAWINGS (2 Pages)**

---

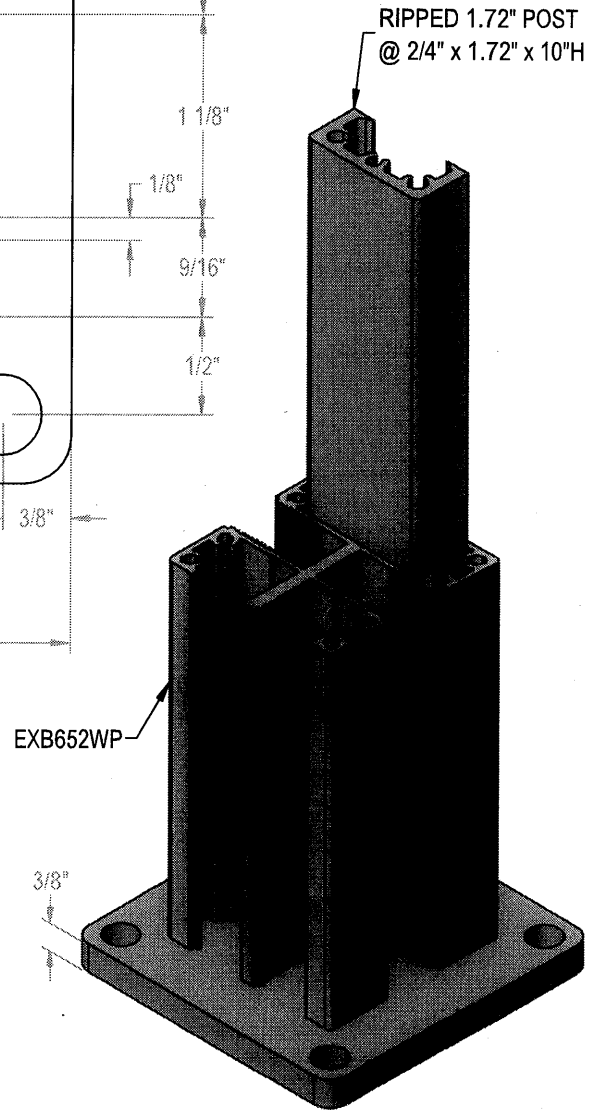
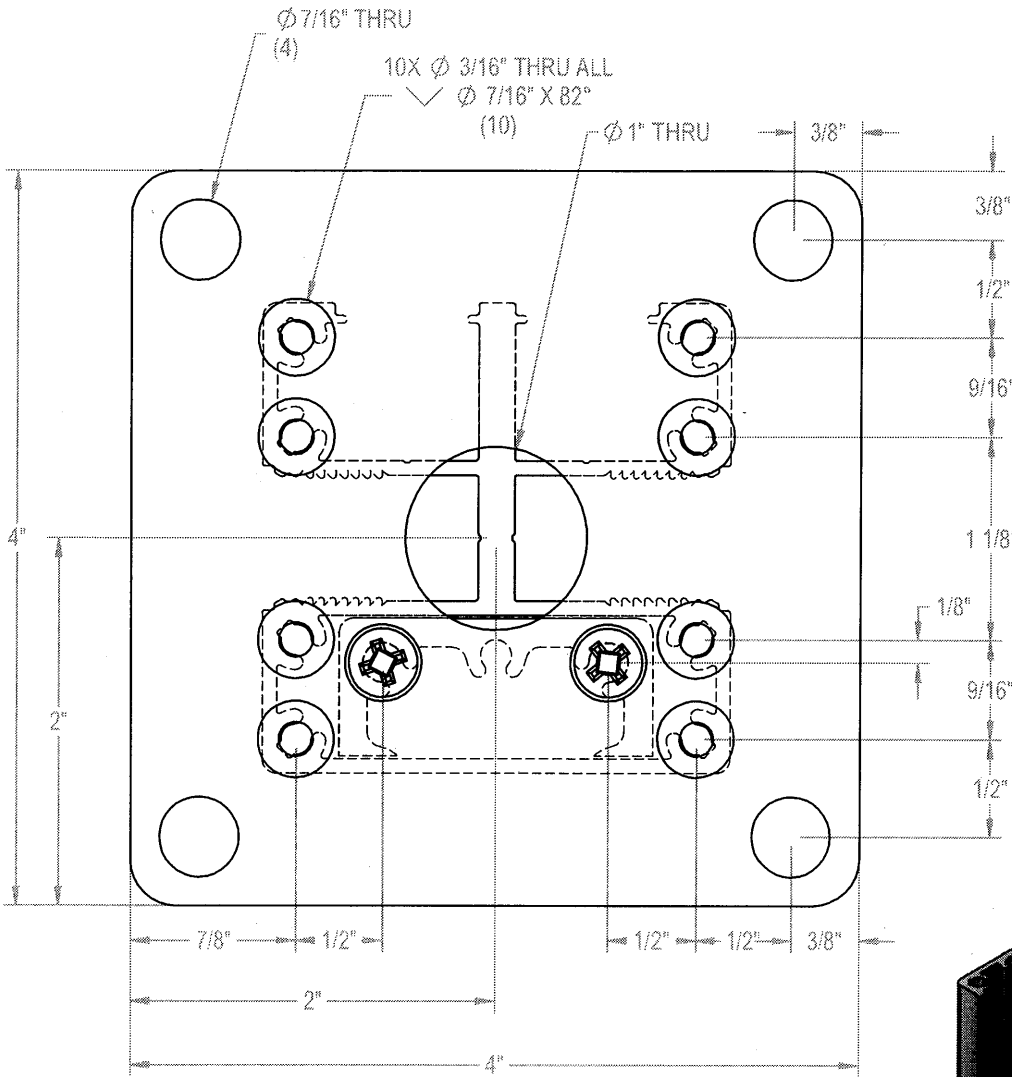

**Intertek**  
 Valued Quality In Every Detail.  
 Test sample complies with these details.  
 Deviations are noted.  
 Report #: 10329570700Q-001D  
 Date: 02/14/17 Tech: *[Signature]*

PLEASE NOTE THAT ALL DIMENSIONS ARE SUBJECT TO SITE MEASUREMENTS AND ARE TO BE CONFIRMED BEFORE FABRICATION OF PRODUCT

**EXCELL**  
 RAILING SYSTEMS LTD  
 Excell Railing Systems Ltd.  
 #306 - 12886 Anvil Way  
 Surrey, BC Canada V3W 8E7  
 Phone: 604-501-0151 Fax: 604-501-0155  
 Toll Free: 1-866-999-7245  
 www.excellrailing.com

Authorization Signature \_\_\_\_\_ Date of Authorization \_\_\_\_\_

MANUFACTURER OF EXCELL & DURARAIL PRODUCT LINES

Drawing Name 1.72 Ripped Post Assembly  
 Customer Excell Railing

**Durarail**  
 Durarail Kansas City Warehouse  
 1722 Iron Street  
 North Kansas City, MO 64116  
 Toll Free: 1-800-338-3568  
 Fax: 1-816-421-2924  
 www.durarail.com

Project Name Product Development  
 Drawn By Rolly Gatus Date Created May 2, 2017  
 Revision No. - Scale NTS Last Update

THE MATERIAL CONTAINED HEREIN IS PROPRIETARY TO EXCELL RAILING SYSTEMS LTD. AND SHALL NOT BE REPRODUCED, DISCLOSED OR USED FOR ANY OTHER PURPOSE WITHOUT THE WRITTEN APPROVAL OF EXCELL RAILING SYSTEMS LTD.

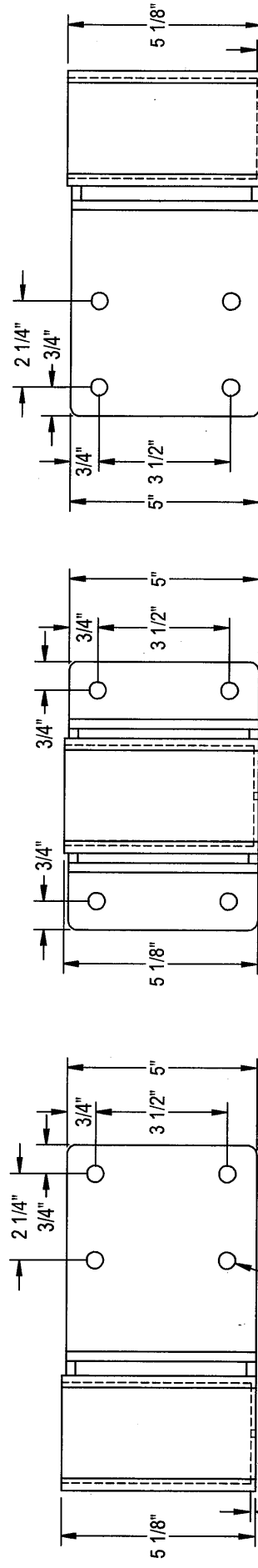
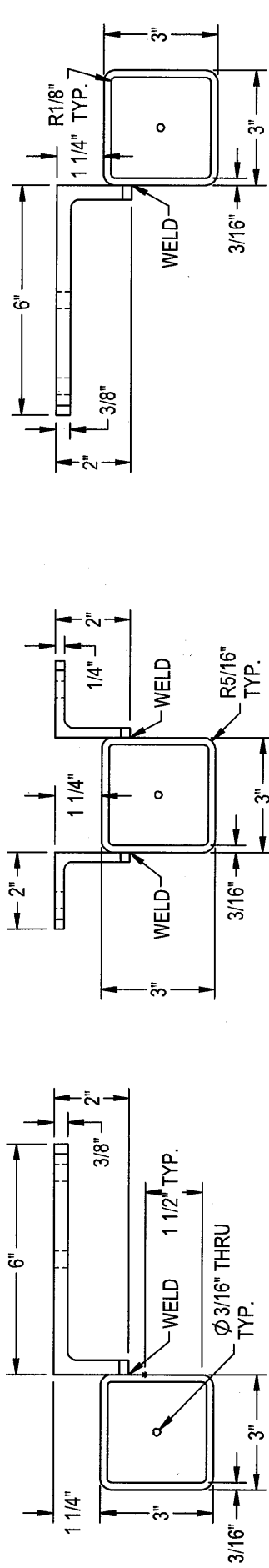

**Intertek**  
**RIGHT END POST SLEEVE**  
Verified Quality. Unsurpassed.  
**Test sample complies with these details.**  
 Deviations are noted.  
 Report #: 10329570700Q-001D  
 Date: 12/14/17 Tech: RL

INLINE POST SLEEVE

LEFT END POST SLEEVE

\* ONLY INLINE POST SLEEVE TESTED

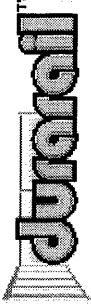
<b>EXCELL</b> RAILING SYSTEMS LTD MANUFACTURER OF EXCELL & DURARAIL PRODUCT LINES 	Authorization Signature Durarail Kansas City Warehouse 1722 Iron Street North Kansas City, MO 64116 Toll Free: 1-800-338-3568 Fax: 1-816-421-2924 www.durarail.com	Date of Authorization	Drawing Name: Knotwood Fascia Post Sleeve Details Customer: Excell Railing Project Name: Product Development Drawn By: Rolly Gatus Revision No.: 1 Scale: NTS Date Created: December 12, 2016 Last Update: March 23, 2017
	ALL DIMENSIONS ARE SUBJECT TO SITE MEASUREMENTS AND ARE TO BE CONFIRMED BEFORE FABRICATION OF PRODUCT		